

BETA

SERIES



INFINITY BETA™ SPEAKER SYSTEMS

Owner's Guide

Beta 10

Beta 20

Beta 40

Beta 50

Beta C250

Beta C360



INFINITY BETA SERIES

The Infinity Beta™ Series of loudspeakers continues Infinity's longstanding commitment to accurate sound reproduction. Our patented Ceramic Metal Matrix Diaphragm (CMMD™) drivers, precision dividing networks, and rigid, well-braced enclosures, along with our newly developed, patent-pending Constant Acoustical Impedance™ (CAI™) waveguide, combine to deliver uncompromised performance in any stereo or multichannel home theater system. In addition, Beta Series speakers are magnetically shielded for safe placement adjacent to a television.

UNPACKING THE SPEAKERS

If you suspect damage from transit, report it immediately to your dealer. Keep the shipping carton and packing materials for future use.

PLACEMENT

Stereo

Before deciding where to place your Beta speakers, survey your room and think about placement, keeping the following points in mind, using Figure 1 as a guide:

- For best results, place the speakers 6'–8' (1.5m–2.5m) apart.
- Position each speaker so that the tweeter is approximately at ear level.
- Generally, bass output will increase as the speaker is moved closer to a wall or corner.
- Refer to "Home Theater" below if you also plan to use the speakers for home theater reproduction.

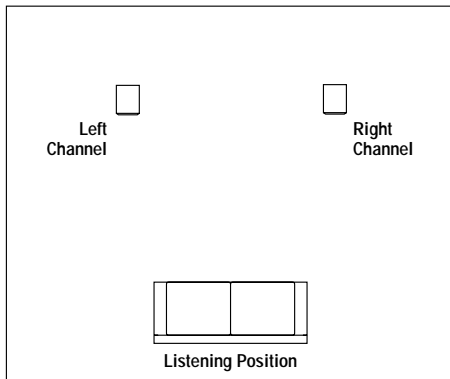

Figure 1. Experiment with speaker placement to obtain the best bass level and stereo imaging in your room.

Home Theater

For front-channel use, place one speaker on the left and another on the right, along either side of the television monitor. Since the speakers are magnetically shielded, you can place them near the TV without worrying about the field distorting the TV picture.

For surround-channel use, place speakers on bookshelves or stands alongside the listening position. Final placement depends on room acoustics, availability of space and your listening preference (Figures 2 and 3).

In 6- or 7-channel configurations, place the rear channel(s) behind the listening position, as shown in Figures 2 and 3.

NOTE: An Infinity powered subwoofer will add impact and realism to both music and film soundtracks. Contact your Infinity dealer for recommendations on subwoofer models for your application.

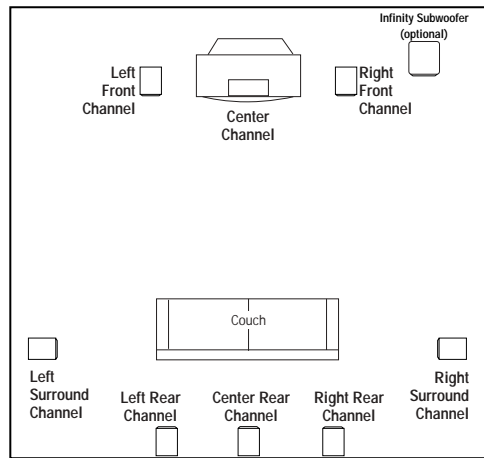

Figure 2. This overhead view shows a typical home theater plan. Left/right rear channels are for a 7-channel system. Center rear channel is for a 6-channel system.

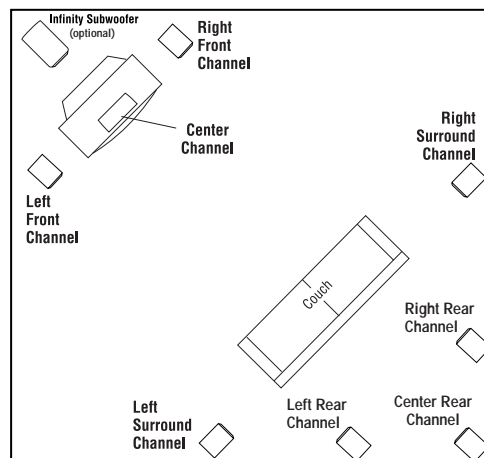

Figure 3. This figure shows an alternate layout, which may be more suitable for some rooms. Left/right rear channels are for a 7-channel system. Center rear channel is for a 6-channel system.

INSTALLING FEET

Beta 40 and Beta 50

These models feature four rubber feet that enable them to be placed on a smooth-surfaced floor, such as tile or hardwood. Four metal spikes are supplied for use when the speaker is to be placed on a carpeted surface to decouple the speaker from the floor and prevent unwanted damping. To insert the spikes, gently lay the speaker on its side (not its front or back) on a soft, nonabrasive surface. Each spike screws into the threaded insert in the center of each rubber foot. Make sure all four spikes are screwed in completely for stability.

NEVER drag the speaker to move it, as this will damage the spikes, the feet and/or the wood cabinet itself. Always lift the speaker and carry it to its new location.

CAUTION: Floorstanding (tower) loudspeakers have a high center of gravity and may become unstable and tip over during earthquakes, or if rocked, tipped or improperly positioned. If this is a concern, these speakers should be anchored to the wall behind them, using the same procedures and hardware customary for anchoring bookcases and wall units. The customer is responsible for proper installation and proper selection of hardware.

WIRING THE SYSTEM

IMPORTANT: Make sure all equipment is turned off before making any connections.

For speaker connections, use a high-quality speaker wire with polarity coding. The side of the wire with a ridge or other coding is usually considered positive polarity (i.e., +).

NOTE: If desired, consult your local Infinity dealer about speaker wire and connection options.

The speakers have coded terminals that accept a variety of wire connectors. The most common connection is shown in Figure 4.

To ensure proper polarity, connect each + terminal on the back of the amplifier or receiver to the respective + (red) terminal on each speaker, as shown in Figure 5. Connect the - (black) terminals in a similar way. See the owner's guides that were included with your amplifier, receiver and television to confirm connection procedures.

IMPORTANT: Do not reverse polarities (i.e., + to - or - to +) when making connections. Doing so will cause poor imaging and diminished bass response.

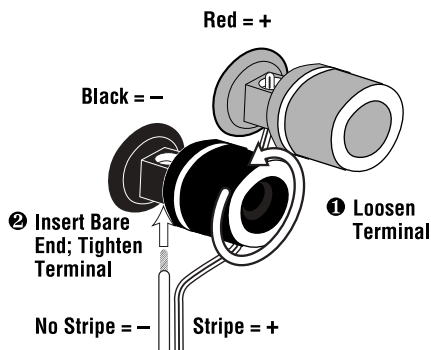

Figure 4. This figure shows how to connect bare wires to the terminals.

Beta 10, Beta 20, Beta C250 and Beta C360

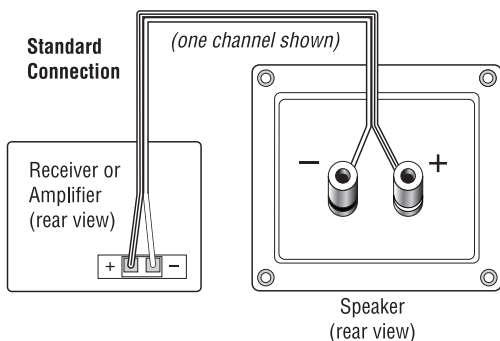

Figure 5. Wiring diagram shows polarity connections for one channel of a stereo or home theater system.

Beta 40 and Beta 50

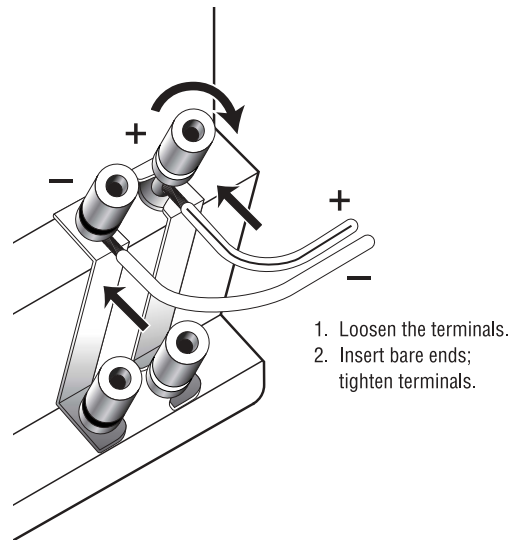

Figure 6. This example shows how to connect bare wires to the terminals. Banana plugs may also be inserted directly into the rear of the connector.

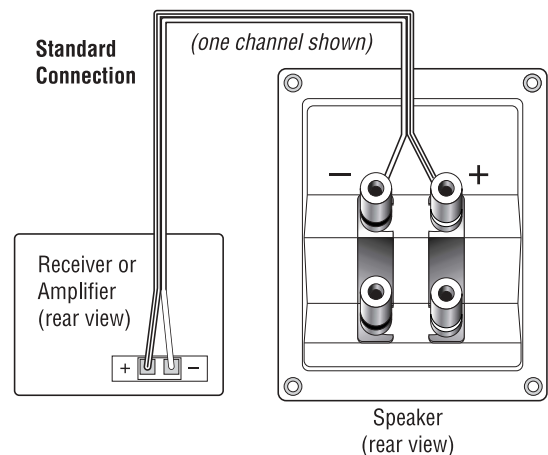

Figure 7. Wiring diagram shows polarity connections for one channel of a stereo or home theater system.

BI-WIRING

The outer connection panel and internal dividing network of the Beta 40 and Beta 50 are designed so that separate sets of speaker cables can be attached to the low-frequency transducer and midrange/high-frequency transducer portions of this dividing network. This is called bi-wiring. Bi-wiring can provide several sonic advantages and considerably more flexibility in power amplifier selection.

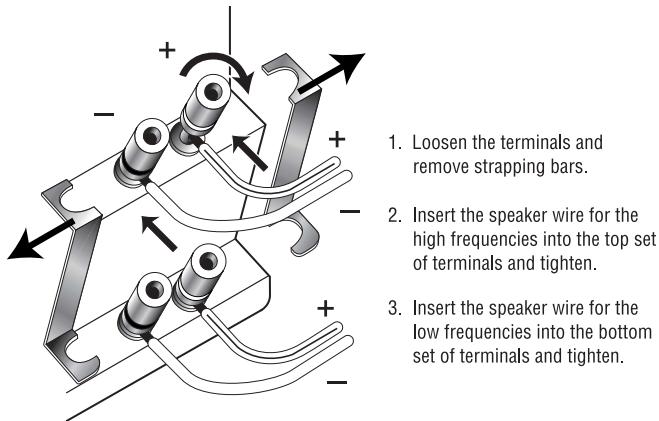

FIGURE 8.

Single-Stereo Amplifier

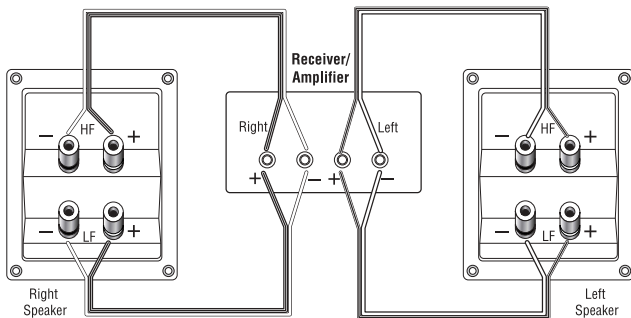

FIGURE 9.

Dual-Stereo Amplifier

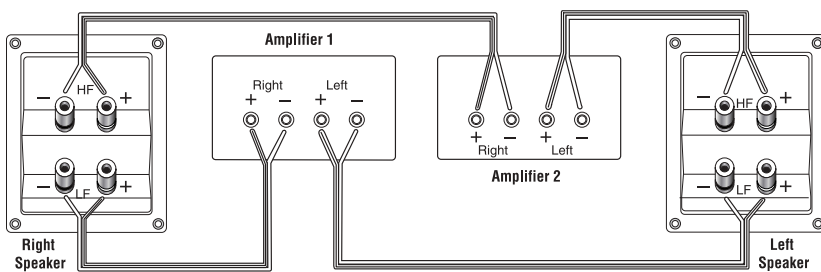

FIGURE 10.

FINAL ADJUSTMENTS

Check the speakers for playback, first by setting the system volume control to a minimum level, and then by applying power to your audio system. Play a favorite music or video segment and increase the system volume control to a comfortable level.

NOTE: You should hear balanced audio reproduction across the entire frequency spectrum. If not, check all wiring connections or consult the authorized Infinity dealer from whom you purchased the system for more help.

The amount of bass you hear and the stereo-image quality will be affected by a number of different factors, including the room's size and shape, the construction materials used to build the room, the listener's position relative to the speakers, and the position of the speakers in the room.

Listen to a variety of music selections and note the bass level. If there is too much bass, move the speakers away from nearby walls. Conversely, if you place the speakers closer to the walls, there will be more bass output.

Nearby reflecting surfaces can adversely affect stereo-imaging quality. If this happens, try angling the speakers slightly inward toward the listening position until the optimum effect is achieved.

CARE OF YOUR SPEAKER SYSTEM

Each Beta Series enclosure has a wood-grain-vinyl finish that does not require any routine maintenance. When needed, use a soft cloth to remove any fingerprints or dust from the enclosure or grille.

NOTE: Do not use any cleaning products or polishes on the cabinet or grille.

SPECIFICATIONS

	Beta 10	Beta 20	Beta 40
Frequency Ranges:	60Hz – 20kHz (± 3 dB) 55Hz – 40kHz (-6 dB)	58Hz – 20kHz (± 3 dB) 52Hz – 40kHz (-6 dB)	45Hz – 20kHz (± 3 dB) 40Hz – 40kHz (-6 dB)
Recommended Amplifier Power Range:	10 – 125 Watts	10 – 150 Watts	10 – 200 Watts
Sensitivity: (2.83V @ 1 meter)	88dB	90dB	91dB
Nominal Impedance:	8	8	8
Crossover Frequency:	2.8kHz; 24dB/octave	2.4kHz; 24dB/octave	600Hz, 3.2kHz; 24dB/octave
Low-Frequency Driver(s):	5" (130mm) CMMD, magnetically shielded	6-1/2" (165mm) CMMD, magnetically shielded	Dual 6-1/2" (165mm) CMMD, magnetically shielded
Mid-Frequency Driver:	NA	NA	5" (130mm) CMMD, magnetically shielded
High-Frequency Driver:	1" (25mm) CMMD, magnetically shielded	1" (25mm) CMMD, magnetically shielded	1" (25mm) CMMD, magnetically shielded
Dimensions (H x W x D): (with grille)	11-13/16" x 7-1/2" x 11-7/16" (300mm x 190mm x 290mm)	13-3/4" x 8-7/8" x 13" (350mm x 225mm x 330mm)	37" x 9-13/16" x 13-1/8" (950mm x 250mm x 333mm)
Weight:	14 lb (6.4kg)	20.7 lb (9.4kg)	50.2 lb (22.8kg)

	Beta 50	Beta C250	Beta C360
Frequency Ranges:	35Hz – 20kHz (± 3 dB) 30Hz – 40kHz (-6 dB)	55Hz – 20kHz (± 3 dB) 50Hz – 40kHz (-6 dB)	45Hz – 20kHz (± 3 dB) 40Hz – 40kHz (-6 dB)
Recommended Amplifier Power Range:	10 – 250 Watts	10 – 150 Watts	10 – 200 Watts
Sensitivity: (2.83V @ 1 meter)	91dB	90dB	91dB
Nominal Impedance:	8	8	8
Crossover Frequency:	600Hz, 3.3kHz; 24dB/octave	2.4kHz; 24dB/octave	500Hz, 3.2kHz; 24dB/octave
Low-Frequency Driver(s):	Dual 8" (200mm) CMMD, magnetically shielded	Dual 5" (130mm) CMMD, magnetically shielded	Dual 6-1/2" (165mm) CMMD, magnetically shielded
Mid-Frequency Driver:	5" (130mm) CMMD, magnetically shielded	NA	4" (100mm) CMMD, magnetically shielded
High-Frequency Driver:	1" (25mm) CMMD, magnetically shielded	1" (25mm) CMMD, magnetically shielded	1" (25mm) CMMD, magnetically shielded
Dimensions (H x W x D): (with grille)	41-5/16" x 10-7/16" x 14-11/16" (1050mm x 265mm x 372mm)	6-11/16" x 17" x 8-3/8" (170mm x 430mm x 212mm)	8-1/2" x 25-5/8" x 11-3/4" (215mm x 650mm x 298mm)
Weight:	62.5 lb (28.4kg)	16 lb (7.3kg)	34.5 lb (15.7kg)

Infinity continually strives to update and improve existing products, as well as create new ones. The specifications and construction details in this and related Infinity publications are therefore subject to change without notice.

NOTES

Declaration of Conformity



We, Harman Consumer International
2, route de Tours
72500 Chateau-du-Loir
France

declare in own responsibility that the products described
in this owner's manual are in compliance with technical
standards:

EN 50081-1:1992

EN 50082-1:1997

A handwritten signature in blue ink, appearing to read 'Robin Marshall'.

Robin Marshall
Harman Consumer International
Chateau-du-Loir, France 11/03



TECHNOLOGY • PERFORMANCE • DESIGN

© 2003 Harman International Industries, Incorporated

Infinity Systems, 250 Crossways Park Drive, Woodbury, NY 11797 USA 516.674.4INF (4463) www.infinitysystems.com

Infinity is a registered trademark, and Infinity Beta and CMMD (patent nos. 6,327,372 and 6,404,897) are trademarks, of Harman International Industries, Incorporated.

Part No. TK 11/03

H A Harman International Company